

SCHMEISER®
TANDEM DISC
ASSEMBLY & PARTS
MANUAL

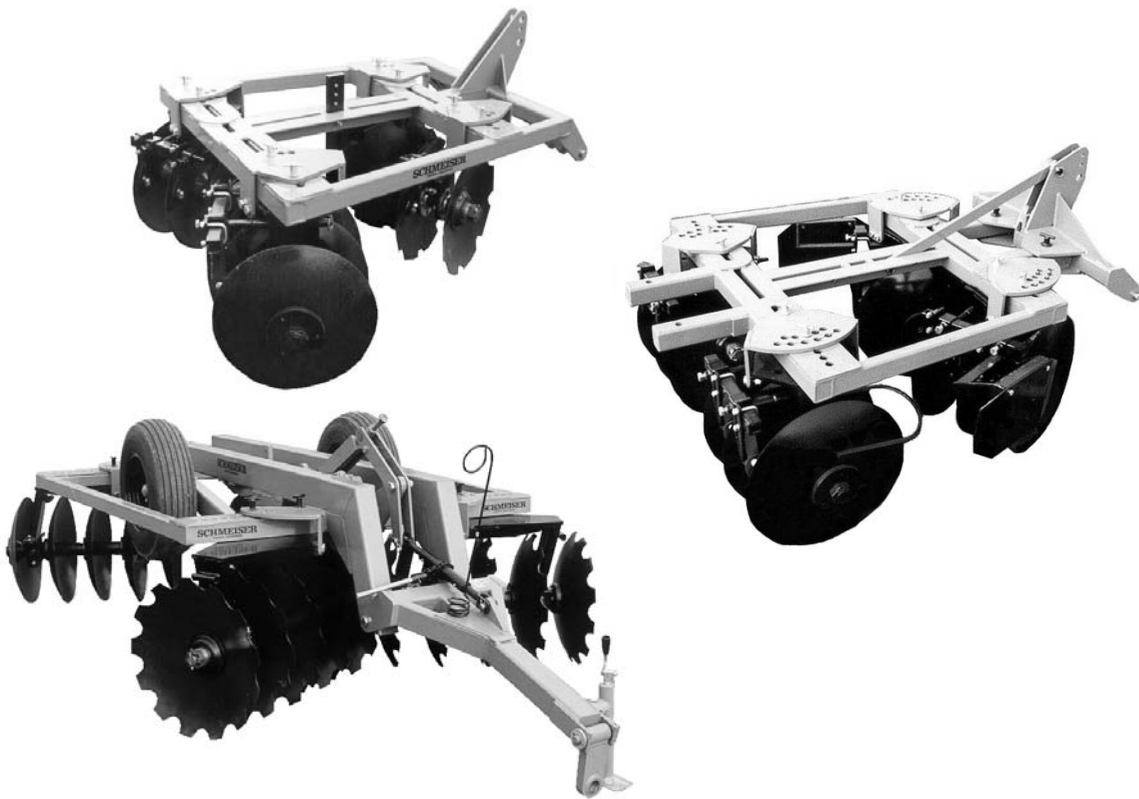

3pt. models: **TSN™**, **RTM™**, & **RTH™**
Pull Type models: **PTM™** & **PTH™**

T. G. SCHMEISER CO., INC.

P.O. BOX 1047 FRESNO, CA 93714-1047

(559) 268-8128 FAX (559) 268-3279

www.tgschmeiser.com

VERSION 1.4
NOV. 2014

INTRODUCTION

Your Schmeiser Tandem Disc™ is designed to give you many years of dependable service. This manual has been prepared to instruct you in the safe and efficient operation of this machine. Read and study it thoroughly. Follow all instructions carefully.

Should your Tandem Disc require replacement parts, go to your Schmeiser® dealer. Always order genuine Schmeiser replacement parts.

It is important that you complete and send in your Warranty Card because it is not valid unless it is on file at Schmeiser. If you need information not contained in this manual, contact your Schmeiser dealer.

This manual covers the following Schmeiser Tandem Disc models: TSN™, RTM™, RTH™, PTM™, and PTH™. Use the table of contents as a guide to locate the proper information for your selected model.

Space has been provided below for you to record the model number and serial number of your Schmeiser Tandem Disc. Be sure to bring this information with you to your dealer when ordering parts or attachments for your Tandem Disc.

Thank you for buying a Schmeiser Tandem Disc™.

SERIAL NUMBER _____

MODEL NUMBER _____

DATE PURCHASED _____

DEALER NAME _____

SCHMEISER® reserves the right to make improvements in design or changes in specification at any time without incurring any obligation to owners of equipment previously sold.

Copyright © 2005. T. G. Schmeiser Co., Inc. All rights reserved. This manual, or parts thereof, may not be reproduced in any form without permission.

TABLE OF CONTENTS

Introduction.....	2
Table of Contents.....	3
Disc Models (covered in this manual).....	4
Safety Sheet.....	5
TSN Main Frame Parts.....	6
RTM Main Frame Parts.....	7
RTH Main Frame Parts.....	8
PTM & PTH Main Frame Parts.....	9
PTM & PTH Leveling Spring Assembly.....	10
2 Blade Gang Assembly.....	11
3 Blade Gang Assembly.....	12
4 Blade Gang Assembly.....	13
5 Blade Gang Assembly.....	14
Disc Scraper Assembly.....	15
Disc Dirt Diverter Assembly.....	16
Trunnion Bearing Assembly.....	17
Trunnion Bearing Assembly Complete.....	18
Blade Extension Diagram.....	19
Inside Blade Extension Assembly.....	20
Outside Blade Extension Assembly.....	21
Limited Warranty.....	22
Maintenance and Repair Record.....	23
Notes.....	24

SCHMEISER[®]

TANDEM DISC MODELS

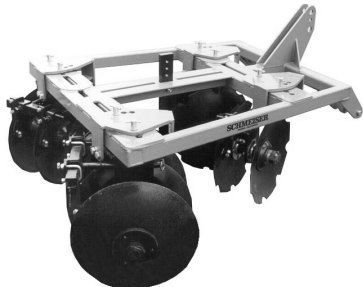

TSN – TANDEM SUPER NARROW™

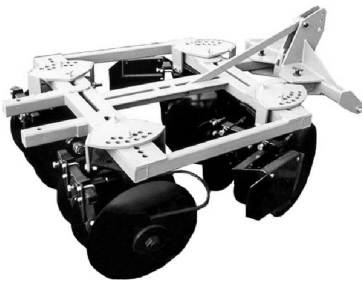

RTM – REVERSIBLE TANDEM MEDIUM™

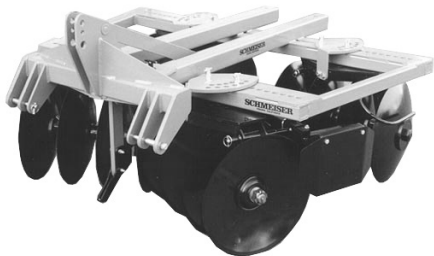

RTH – REVERSIBLE TANDEM HEAVY™

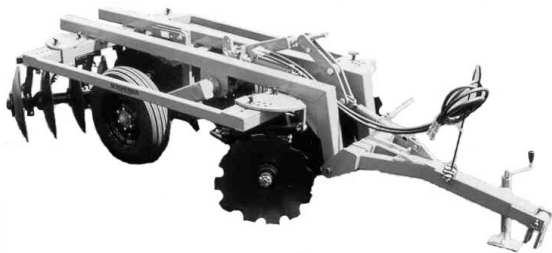

**PTM – PULL TYPE TANDEM MEDIUM
WHEEL DISC™**

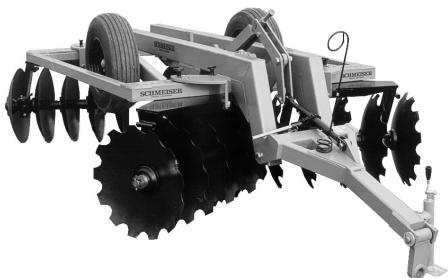

**PTH – PULL TYPE TANDEM HEAVY
WHEEL DISC™**

SAFETY

The safe operation of any machinery is an important concern to farmers and manufactures. There are obvious and hidden potential hazards involved in the operation of this implement. Carefully read and follow all safety precautions before operation. Serious injury or death may occur unless care is taken to insure the safety of both the operator and any other persons in the area.

1. Never permit anyone to ride on or walk beside the implement when moving.
2. Never permit anyone to ride on tractor when implement is being moved.
3. Before starting machine, always check area around machine to verify that all personnel are clear.
4. Never connect hydraulic lines or operate any portion of the machine unless machine is hitched to tractor.
5. Do not operate hydraulic systems when hydraulic leaks are present.
6. Before transport or unhitching, always tie back hydraulic hoses.
7. Do not exceed 2000 psi working pressure or 2500 psi maximum pressure on hydraulic system.
8. When performing operating functions, never allow anyone to be near the implement or the tractor.
9. Do not enter tractor when tractor is moving. Avoid serious injury or death from contact with rotating tires. Enter and exit the tractor only when it is completely stopped.
10. Always operate machine in a careful, controlled manner.
11. Personnel operating and working with this machinery must not wear loose, dangling or unbuttoned clothing which could tangle in machinery.
12. Be sure of water, gas, sewer, or electric line locations before operating implement.
13. When in transport, use accessory lights and devices for adequate warning to operators of other vehicles.
14. Comply with all Federal, State and local laws when traveling on public roads.
15. Use "Slow Moving Vehicle" emblem for warning vehicles approaching from the rear.
16. When transporting, remember that the implement may be wider than your tractor and extreme care must be taken to allow for safe clearance.
17. Never allow inexperienced or untrained personnel to operate the implement or tractor.
18. When using compressed air to clean implement, wear safety glasses.
19. Check all fasteners for tightness or damage before and after operation. Repair immediately if required.
20. Before transport, inspect lug bolts and tire inflation.
21. Store implement in a stable position. Insure that safety stands are extended and locked in place before detaching from tractor. Before unhitching, place chocks in front and behind all transport wheels to prevent rolling when unhitched and parked.
22. Always use two people to handle heavy, unwieldy components during assembly, installation, removal, or moving.

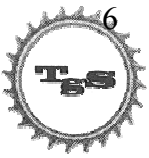

SERIAL NUMBER: _____

MODEL NUMBER: _____

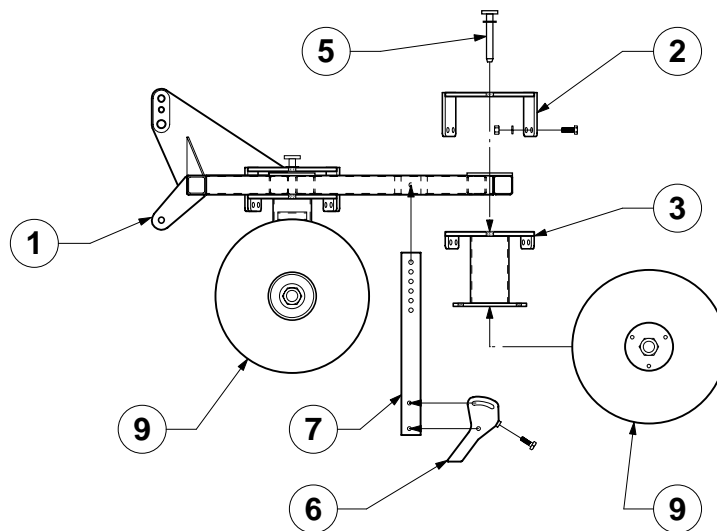
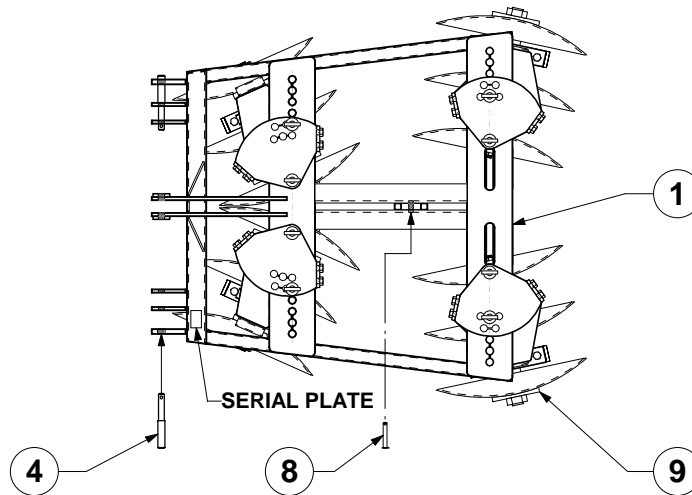

<u>Ref No.</u>	<u>New Part No.</u>	<u>Old Part No.</u>	<u>Description</u>	<u>Qty.</u>
1.	TSN-45A000 TSN-55A000	-----	Main Frame for 45" Units Main Frame for 55" Units	1 1
2.	TSN-00B000L(R)	TSN-B	Gang Top Plate Left and Right	2
3.	TSN-(00)T000L(R)	TSN-T	Gang Frame (Specify Gang Location & Blade Q-ty)	1
4.	GPN-18CA12	RTM-A-18	Category I & II Clevis Pull Pin	2
5.	GDP-00GPIN	RT-C-03	1" Dia. Gang Frame Adjustment Pin	8
6.	GDP-00H100	SD-H-01	Foot Attachment	1
7.	GDP-00H200	SD-H-02	1" x 3" Standard	1
8.	GDP-00H300	SD-H-03	5/8" Dia. Middle Buster Pin	1
9.	-----	-----	Gang Assembly (see Gang Assembly Drawing)	4

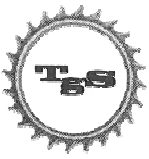

SERIAL NUMBER: _____
 MODEL NUMBER: _____

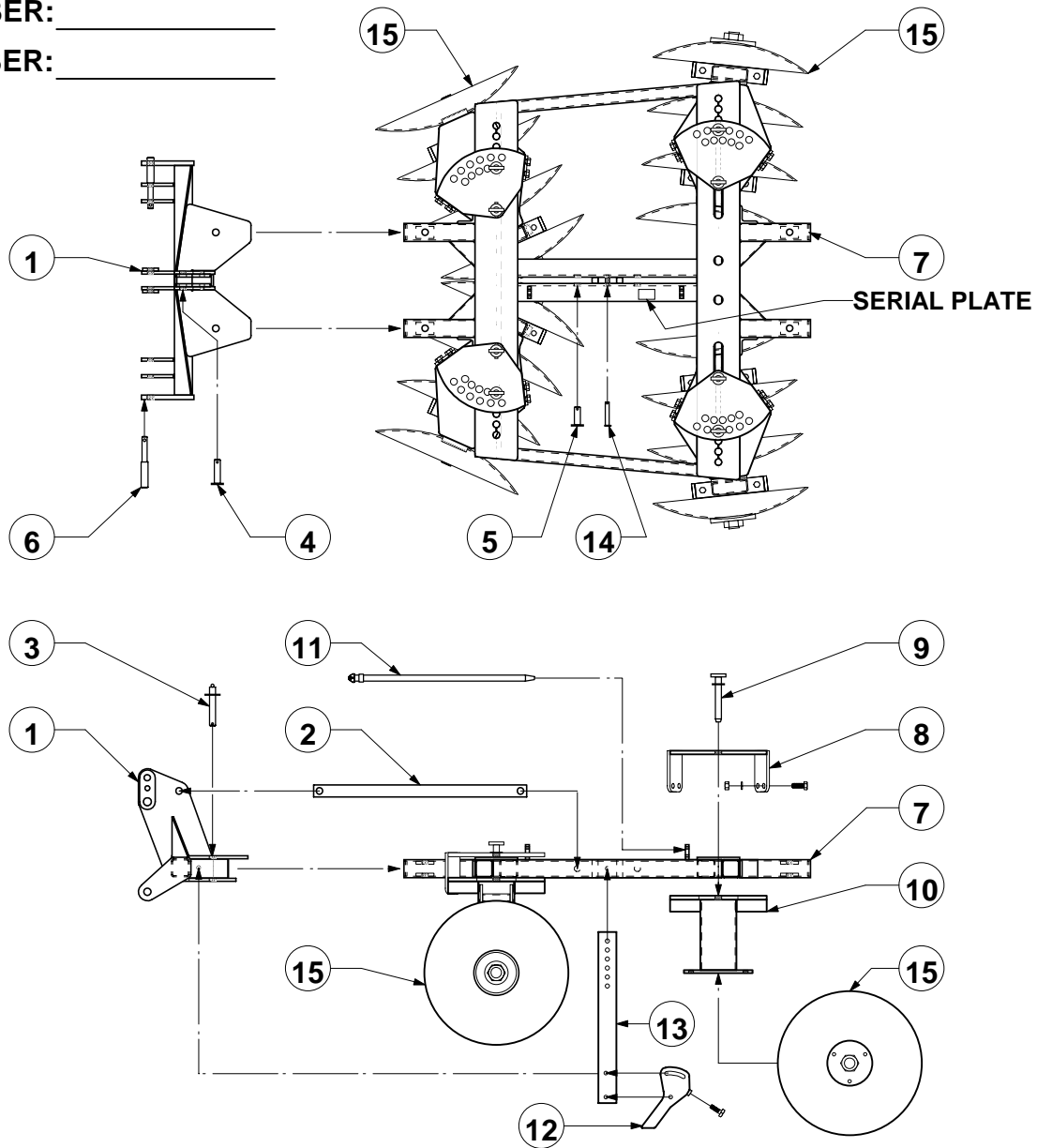

Ref No.	New Part No.	Old Part No.	Description	Qty.
1.	RTM-00A000	RTM-A	Reversable Three Point Hitch	1
2.	RTM-00A014	RTM-A-14	3/4" x 2" Hitch Center Brace	1
3.	GPN-16080L	RTM-A-15	1" Dia. x 5" Hitch Lock Pin	2
4.	GPN-16X068	RT-A-16	1" Dia. x 4-1/4" Brace Clevis Pin	1
5.	GPN-16X048	RT-A-17	1" Dia. x 3" General Clevis Pin	1
6.	GPN-18CA12	RTM-A-18	Category I & II Clevis Pull Pin	2
7.	-----	-----	Main Frame	1
8.	RTU-00C000	RT-C	Reversable Gang Top Plate	4
9.	GDP-00GPIN	RT-C-03	1" Dia. Gang Frame Adjustment Pin	8
10.	RTU-(00)D000L(R)	RT-D	Reversable Gang Frame (Specify Gang Location & Blade Qty.)	4
11.	GDP-00G000	SD-G	Gang Adjustment Rod (for 14 to 20 Blade Units Only)	1
12.	GDP-00H100	SD-H-01	Foot Attachment	1
13.	GDP-00H200	SD-H-02	1" x 3" Standard	1
14.	GDP-00H300	SD-H-03	5/8" Dia. Middle Buster Pin	1
15.	-----	-----	Gang Assembly (see Gang Assembly Drawing)	4



SERIAL NUMBER: _____

MODEL NUMBER: _____

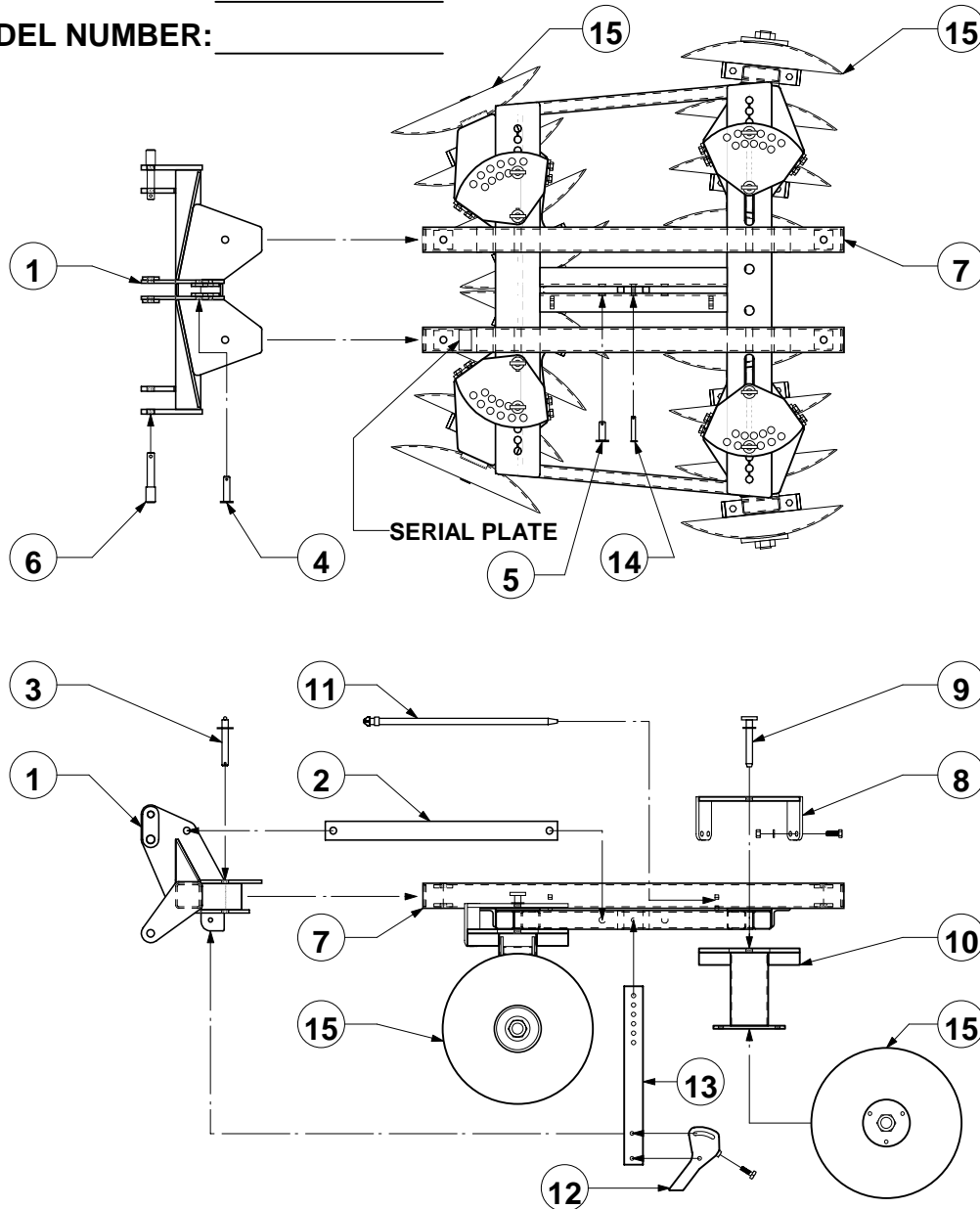

Ref No.	New Part No.	Old Part No.	Description	Qty.
1.	RTH-00A000	RTH-A	Reversible Three Point Hitch	1
2.	RTH-00A014	RTH-A-14	1" x 3" Hitch Center Brace	1
3.	GPN-16096L	RTH-A-15	1" Dia. x 6" Hitch Lock Pin	2
4.	GPN-16X068	RT-A-16	1" Dia. x 4-1/4" Brace Clevis Pin	1
5.	GPN-16X048	RT-A-17	1" Dia. x 3" General Clevis Pin	1
6.	GPN-24CA02	RTH-A-18	Category II Clevis Pull Pin	2
7.	-----	-----	Main Frame	1
8.	RTU-00C000	RT-C	Reversible Gang Top Plate	4
9.	GDP-00GPIN	RT-C-03	1" Dia. Gang Frame Adjustment Pin	8
10.	RTU-(00)D000L(R)	RT-D	Reversible Gang Frame (Specify Gang Location & Blade Qty.)	4
11.	GDP-00G000	SD-G	Gang Adjustment Rod (for 14 to 20 Blade Units Only)	1
12.	GDP-00H100	SD-H-01	Foot Attachment	1
13.	GDP-00H200	SD-H-02	1" x 3" Standard	1
14.	GDP-00H300	SD-H-03	5/8" Dia. Middle Buster Pin	1
15.	-----	-----	Gang Assembly (See Gang Assembly Drawing)	4



SERIAL NUMBER: _____
 MODEL NUMBER: _____

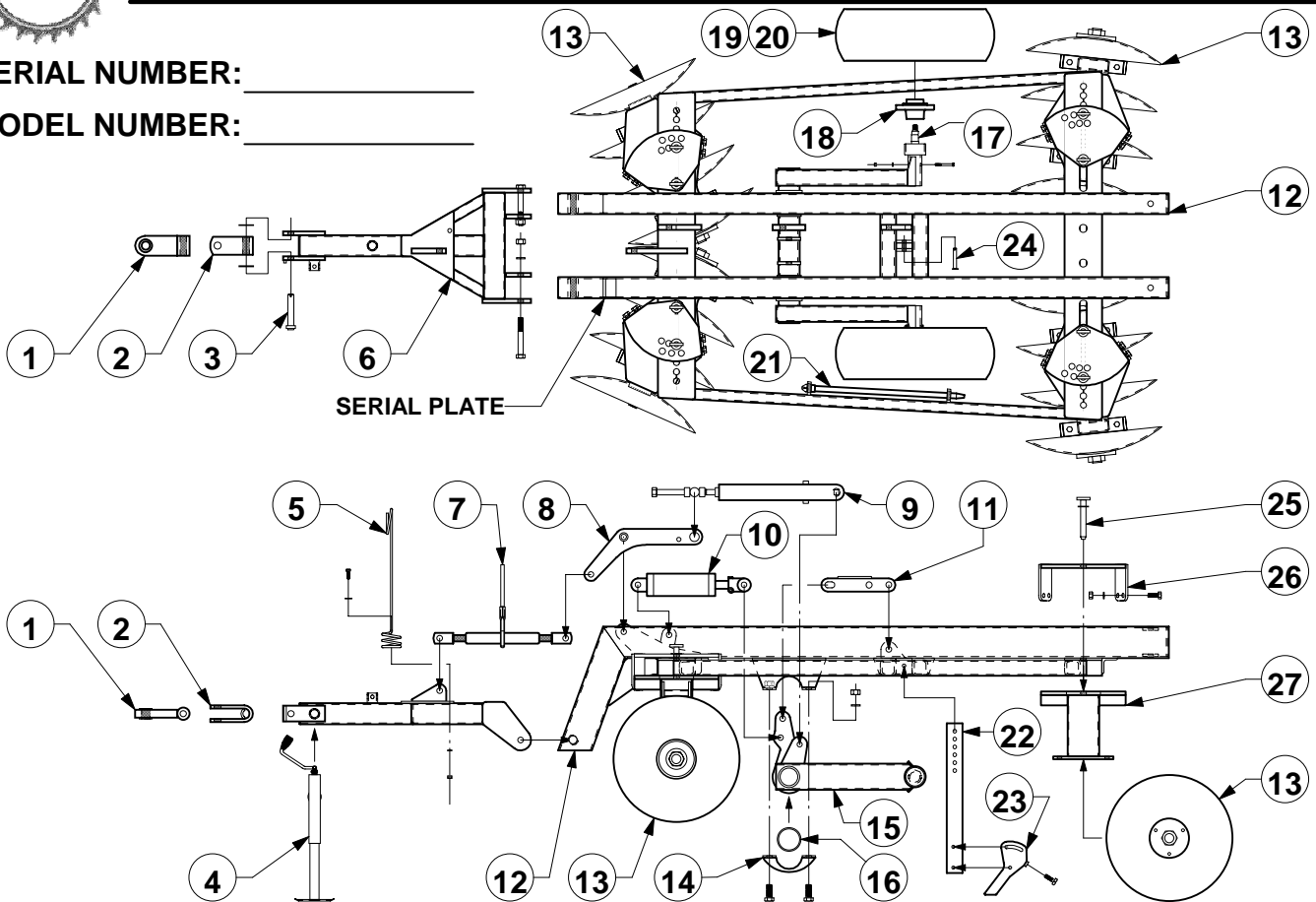

Ref No.	New Part No.	Old Part No.	Description	Qty.
1.	GWD-150SC1	TB4-J2	General Clevis Hitch (for PTH units)	1
2.	GWD-200DC2	TPP 3021	3-1/2" Tongue Clevis (for PTM units)	1
3.	GPN-18A200	PT-A-11	1-1/8" X 6" Clevis Pin	1
4.	GJK-2KTW10	-----	2000 lbs. Capacity Top Winding Jack Stand	1
5.	GHD-HHOLD1	-----	Hydraulic Hose Line Support	1
6.	PTU-00A000	PT-A	Pull Frame	1
7.	GJK-RATCHJ	PT-Q9 *	20" Ratchet	1
8.	PTH-00Q100	PTH-Q1-01	Pivot Link (for PTH units)	2
	PTM-00Q100	PTM-Q1-01	Pivot Link (for PTM units)	2
9.	-----	PT-Q(2-7)	Leveling Adjustment Spring Assembly (See Assembly Drw)	1
10.	GHC-3008SC	3X8SC	3" X 8" Special Stroke Control Hydraulic Cylinder	1
11.	PTU-00Q800	PT-Q8	Lockout Bar	1
12.	-----	-----	Main Frame	1
13.	-----	-----	Gang Assembly (See Gang Assembly Drawing)	4
14.	PTU-00B200	PT-B-22	Tire Axle Bearing Housing Cap	2
15.	PTU-(00)P000	PT-P	Tire Axle Frame (Specify Size)	1
16.	PTU-00P012	PT-P-12	Tire Axle UHMW Bearing	2
17.	PTU-00P011	PT-P-11	2" Replaceable Wheel Spindle	2
18.	GHB-6X6STD	SLL 1415	6 on 6 Hub Assembly (Complete)	2
19.	GWT-156LBH	SLL 1450	15" 6 on 6 Wheel	2
20.	GWT-951508	-----	9.5 x 15 8 Ply Tires (for PTH units)	2
	GWT-761508	-----	7.6 x 15 8 Ply Tires (for PTM units)	2
21.	GDP-00G000	SD-G	Gang Adjustment Rod (for 14 to 20 Blade Units Only)	1
22.	GDP-00H200	SD-H-02	1" X 3" Standard	1
23.	GDP-00H100	SD-H-01	Foot Attachment	1
24.	GDP-00H300	SD-H-03	5/8" Dia. Middle Buster Pin	1
25.	GDP-00GPIN	RT-C-03	1" Dia. Gang Frame Adjustment Pin	8
26.	PTU-00C000L(R)	PT-C	Gang Top Plate (2 L.H. / 2 R.H.)	4
27.	PTU-(00)D000L(R)	PT-D	Gang Frame (Specify Gang Location & Blade Quantity)	4

* NOTE: SPECIFY ITEM DESCRIPTION WHEN USING OLD PART NUMBERS.

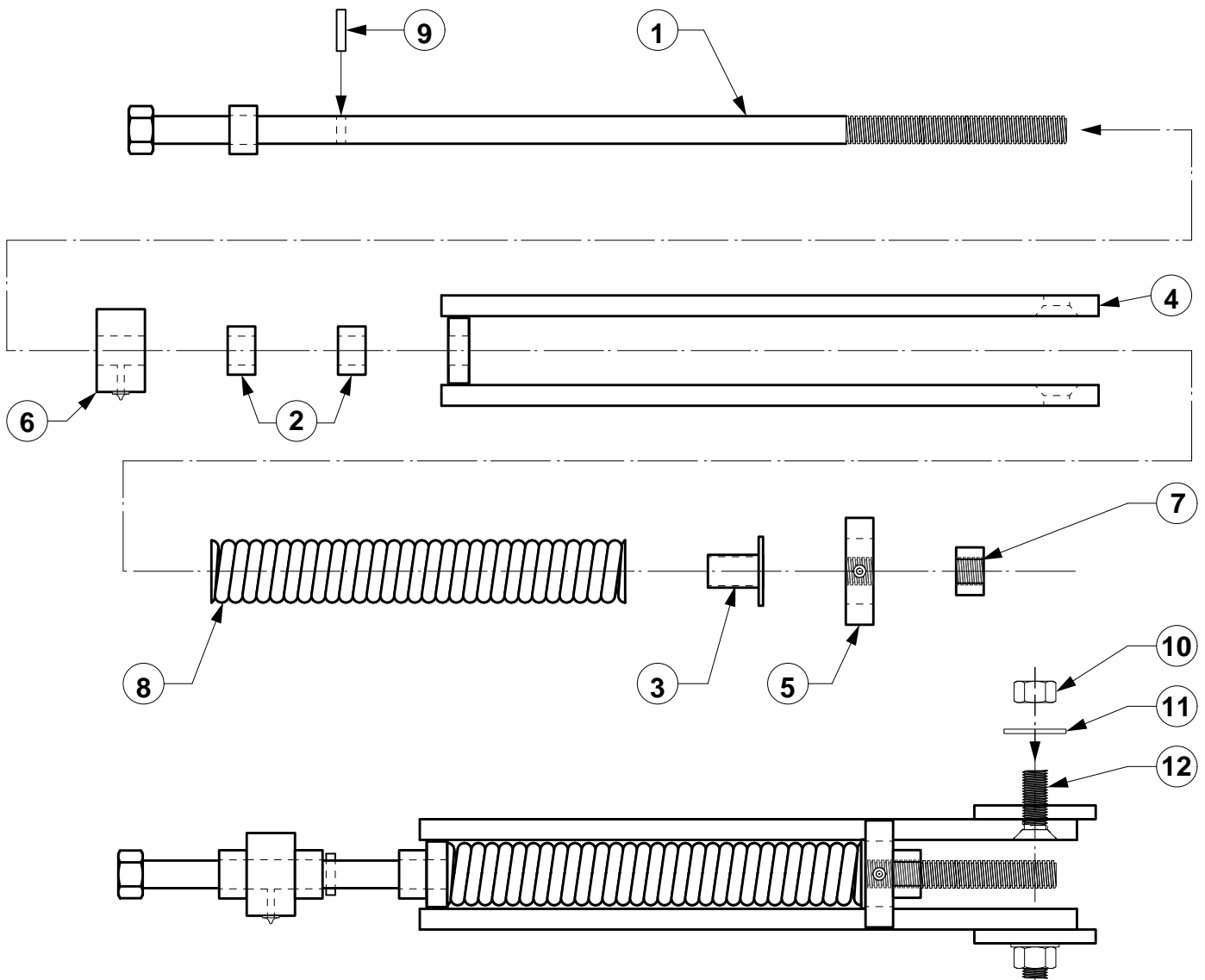

<u>Ref No.</u>	<u>Old Part No.</u>	<u>New Part No.</u>	<u>Description</u>	<u>Qty.</u>
1.	PT-Q2	PTU-00Q200	Leveling Adjustment Bolt	1
2.	PT-Q2-02	PTU-00Q202	Trunnion Bushing	2
3.	PT-Q3	PTU-00Q300	Spring Retainer Bushing	1
4.	PT-Q4	PTU-00Q400	Spring Clevis	1
5.	PT-Q5	PTU-00Q500	Spring Retainer Plate	1
6.	PT-Q6	PTU-00Q600	Adjustment Bolt Trunnion	1
7.	PT-Q7	PTU-00Q700	Adjustment Bolt Jam Nut	1
8.	PT-Q9	GSR-CM0201	2-1/4" Compression Spring	1
9.	PT-Q10	GPN-05X20R	5/16" x 1-1/4" H.D. Roll Pin	1
10.		HXNUTC14NC	7/8" Class "C" NC Hex Lock Nut	2
11.		FWASHER-14	7/8" Flat Washer	2
12.		PBNC814036	7/8" x 2-1/2" Gr.8 NC Plow Bolt	2

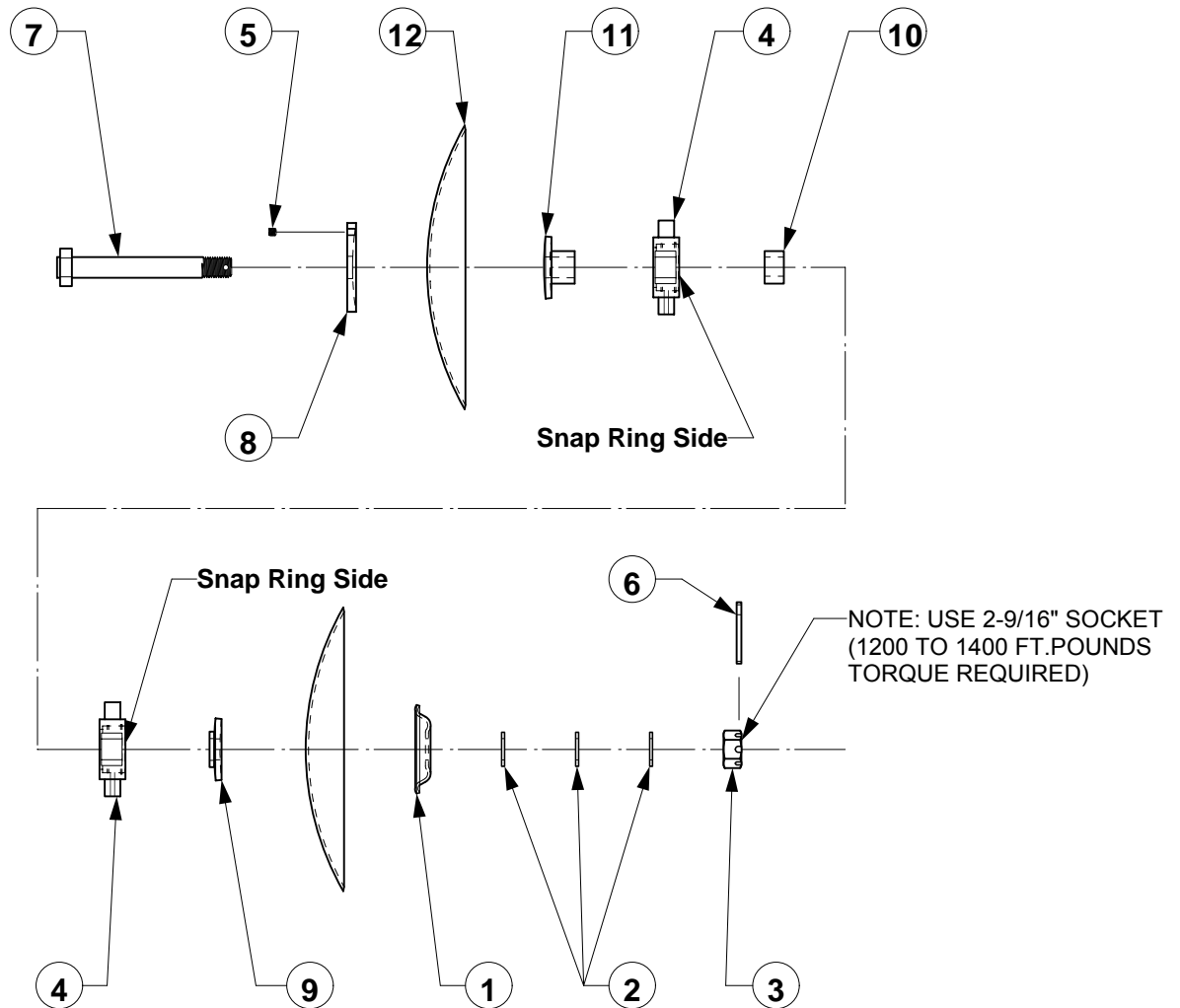

<u>Ref No.</u>	<u>New Part No.</u>	<u>Old Part No.</u>	<u>Description</u>	<u>Qty. / Gang</u>
1.	GDP-28SC01	SD-175A-01	1-3/4" Spring End Collar	1
2.	GDP-28FW01	SD-175A-02	1-3/4" Heavy Flat Washer	3
3.	HXNUTS28NC	SD-175A-03	1-3/4" N.C.Thread Slotted Nut	1
4.	GDP-28TRB0	SD-175-TB	1-3/4" Trunnion Bearing Assembly	2
5.	SSNC-10X10	SD-175A-05	5/8" x 5/8" Set Screw	3
6.	GPN-06X48C	SD-175A-06	3/8" x 3" Usable Cotter Pin	1
7.	GDP-2BB000	SD-175B-2B	1-3/4" 2 Blade Gang Axle	1
8.	GDP-00B003	SD-175B-03	1-3/4" Gang Axle End Plate	1
9.	TSN-00D100	TSN-D2B-01	Concave Bearing Spacer Wldm	1
10.	TSN-00D102	TSN-D2B-02	Middle Bearing Spacer	1
11.	TSN-00D200	TSN-D2B-03	Convex Bearing Spacer Wldm	1
12.	-----	-----	Disc Blade:	
	GDP-22X5DS		22mm x 5mm Disc Blade Smooth	2
	GDP-22X5DN		22mm x 5mm Disc Blade Notched	2

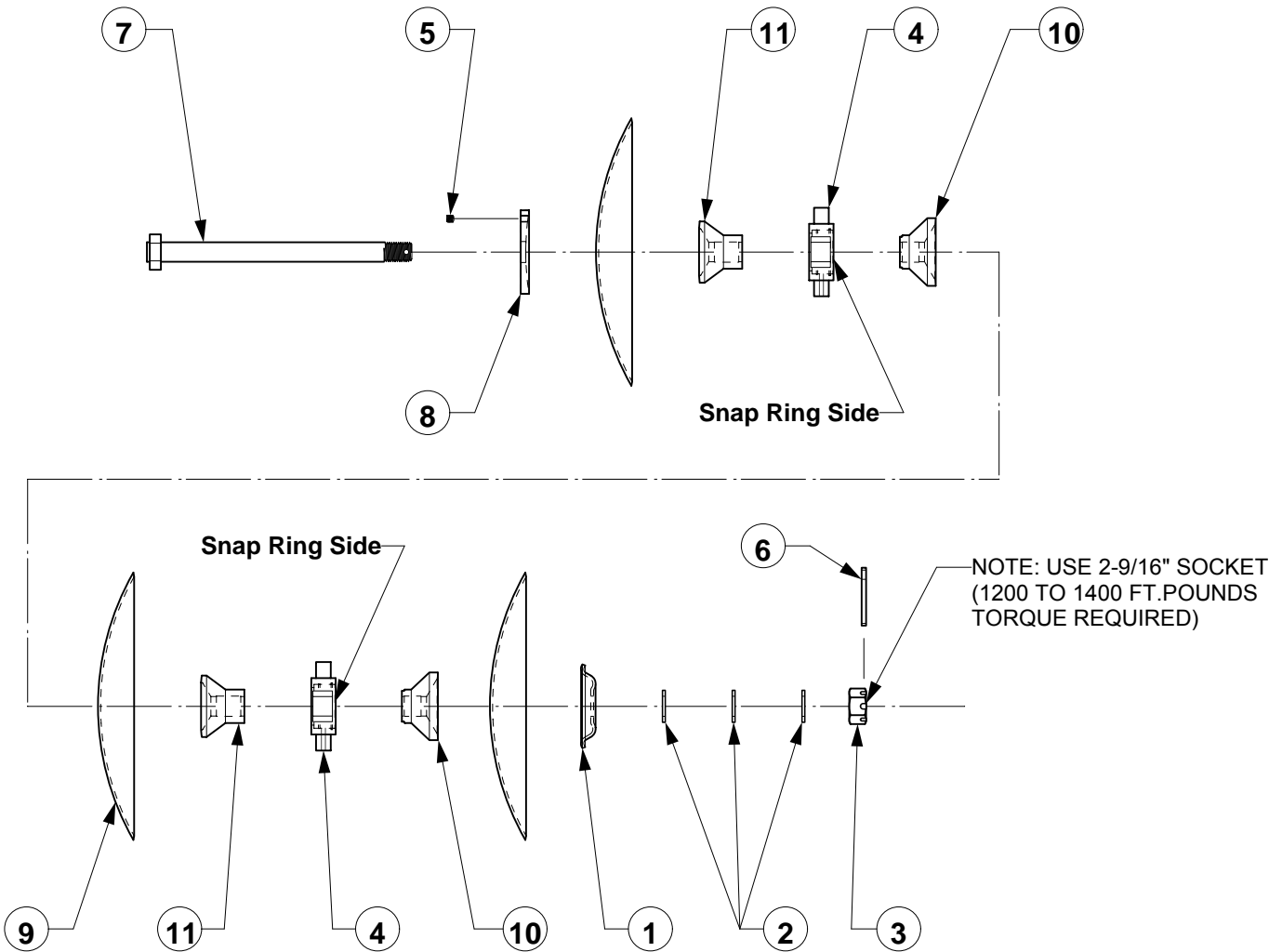

<u>Ref No.</u>	<u>New Part No.</u>	<u>Old Part No.</u>	<u>Description</u>	<u>Qty. / Gang</u>
1.	GDP-28SC01	SD-175A-01	1-3/4" Spring End Collar	1
2.	GDP-28FW01	SD-175A-02	1-3/4" Heavy Flat Washer	3
3.	HXNUTS28NC	SD-175A-03	1-3/4" N.C.Thread Slotted Nut	1
4.	GDP-28TRB0	SD-175-TB	1-3/4" Trunnion Bearing Assembly	2
5.	SSNC-10X10	SD-175A-05	5/8" x 5/8" Set Screw	3
6.	GPN-06X48C	SD-175A-06	3/8" x 3" Usable Cotter Pin	1
7.	GDP-3BB000	SD-175B-3B	1-3/4" 3 Blade Gang Axle	1
8.	GDP-00B003	SD-175B-03	1-3/4" Gang Axle End Plate	1
9.	GDP-22X5DS(N)	-----	22mm x 5mm Disc Blade Smooth (Notched)	3
	GDP-24X5DS(N)		24mm x 5mm Disc Blade Smooth (Notched)	3
	GDP-24X6DS(N)		24mm x 6mm Disc Blade Smooth (Notched)	3
	GDP-26X6DS(N)		26mm x 6mm Disc Blade Smooth (Notched)	3
10.	GDP-28SHS2	SD-175D-01	1-3/4" Short Half Spool	2
11.	GDP-28LHS2	SD-175D-02	1-3/4" Long Half Spool	2

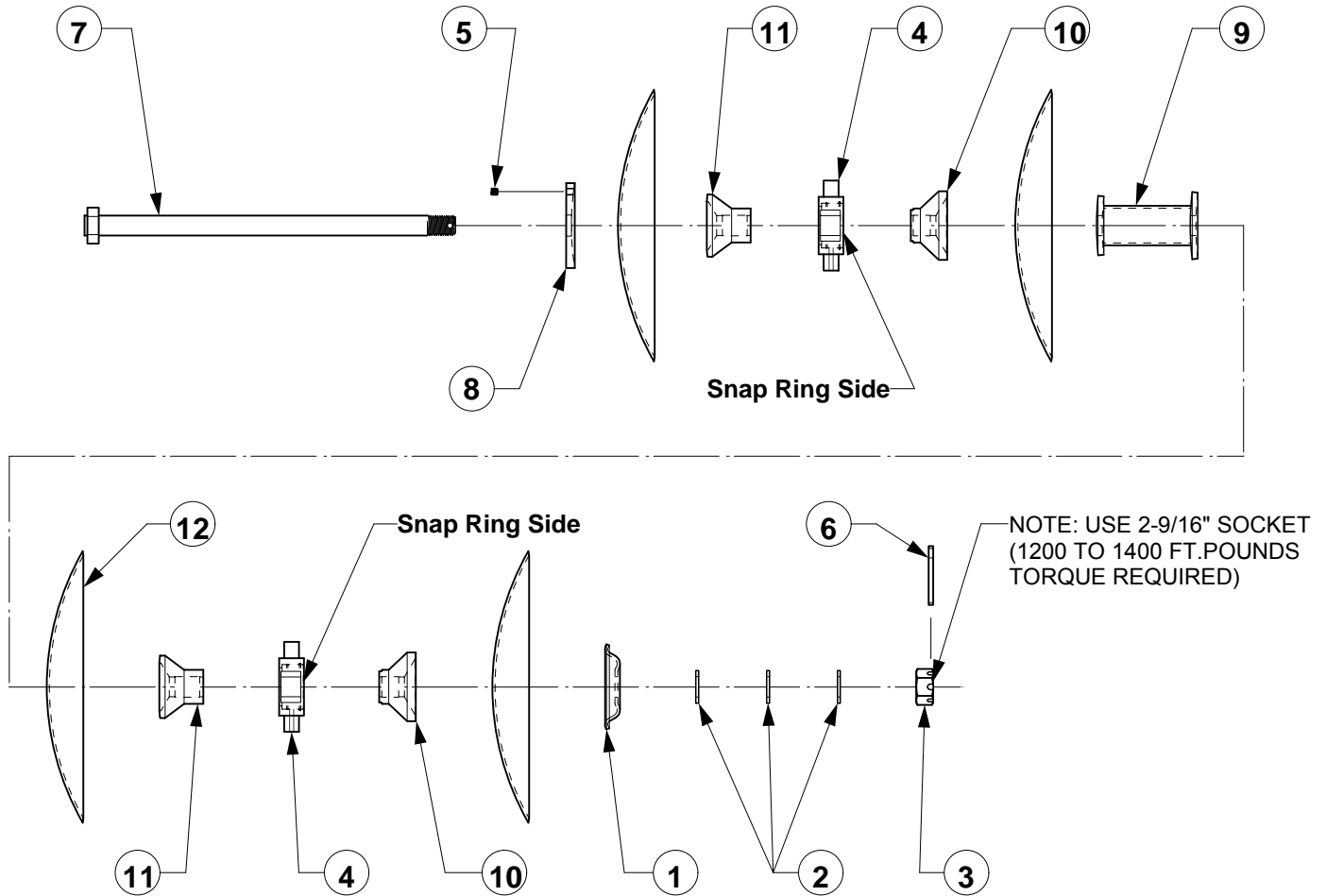

<u>Ref No.</u>	<u>New Part No.</u>	<u>Part No.</u>	<u>Description</u>	<u>Qty. / Gang</u>
1.	GDP-28SC01	SD-175A-01	1-3/4" Spring End Collar	1
2.	GDP-28FW01	SD-175A-02	1-3/4" Heavy Flat Washer	3
3.	HXNUTS28NC	SD-175A-03	1-3/4" N.C.Thread Slotted Nut	1
4.	GDP-28TRB0	SD-175-TB	1-3/4" Trunnion Bearing Assembly	2
5.	SSNC-10X10	SD-175A-05	5/8" x 5/8" Set Screw	3
6.	GPN-06X48C	SD-175A-06	3/8" x 3" Usable Cotter Pin	1
7.	GDP-4BB000	SD-175B-4B	1-3/4" 4 Blade Gang Axle	1
8.	GDP-00B003	SD-175B-03	1-3/4" Gang Axle End Plate	1
9.	GDP-28FS00	SD-175C	1-3/4" Full Spool Wldm	1
10.	GDP-28SHS2	SD-175D-01	1-3/4" Short Half Spool	2
11.	GDP-28LHS2	SD-175D-02	1-3/4" Long Half Spool	2
12.	GDP-24X5DS(N)	-----	24mm x 5mm Disc Blade Smooth (Notched)	4
	GDP-24X6DS(N)		24mm x 6mm Disc Blade Smooth (Notched)	4
	GDP-26X6DS(N)		26mm x 6mm Disc Blade Smooth (Notched)	4

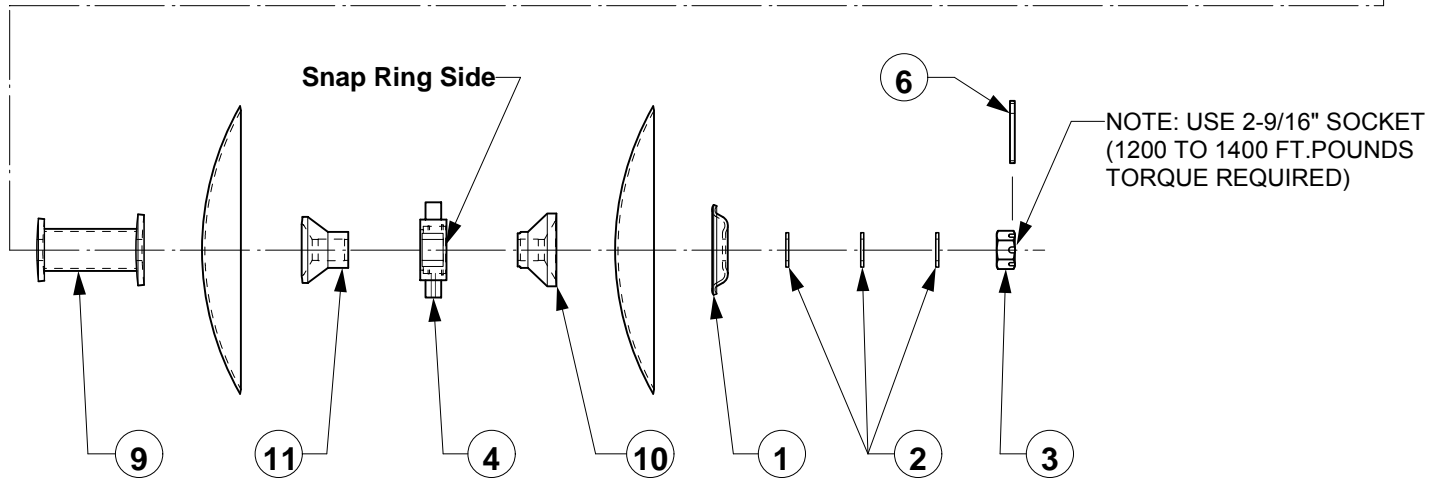
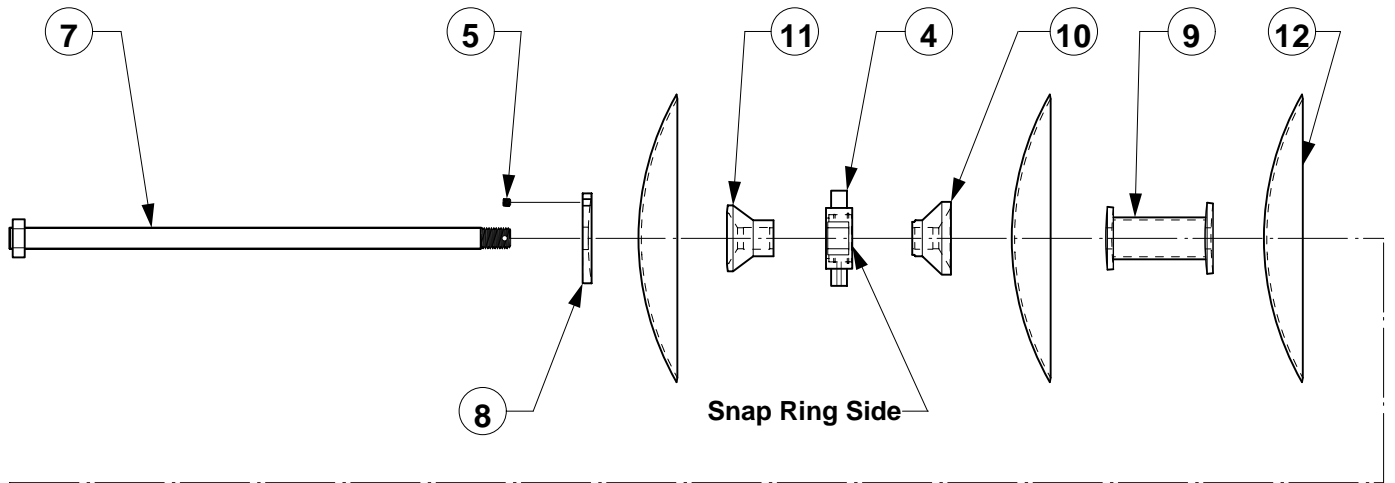

<u>Ref No.</u>	<u>New Part No.</u>	<u>Old Part No.</u>	<u>Description</u>	<u>Qty. / Gang</u>
1.	GDP-28SC01	SD-175A-01	1-3/4" Spring End Collar	1
2.	GDP-28FW01	SD-175A-02	1-3/4" Heavy Flat Washer	3
3.	HXNUTS28NC	SD-175A-03	1-3/4" N.C.Thread Slotted Nut	1
4.	GDP-28TRB0	SD-175-TB	1-3/4" Trunnion Bearing Assembly	2
5.	SSNC-10X10	SD-175A-05	5/8" x 5/8" Set Screw	3
6.	GPN-06X48C	SD-175A-06	3/8" x 3" Usable Cotter Pin	1
7.	GDP-5BB000	SD-175B-5B	1-3/4" 5 Blade Gang Axle	1
8.	GDP-00B003	SD-175B-03	1-3/4" Gang Axle End Plate	1
9.	GDP-28FS00	SD-175C	1-3/4" Full Spool	2
10.	GDP-28SHS2	SD-175D-01	1-3/4" Short Half Spool	2
11.	GDP-28LHS2	SD-175D-02	1-3/4" Long Half Spool	2
12.	GDP-24X5DS(N)	-----	24mm x 5mm Disc Blade Smooth (Notched)	5
	GDP-24X6DS(N)		24mm x 6mm Disc Blade Smooth (Notched)	5
	GDP-26X6DS(N)		26mm x 6mm Disc Blade Smooth (Notched)	5

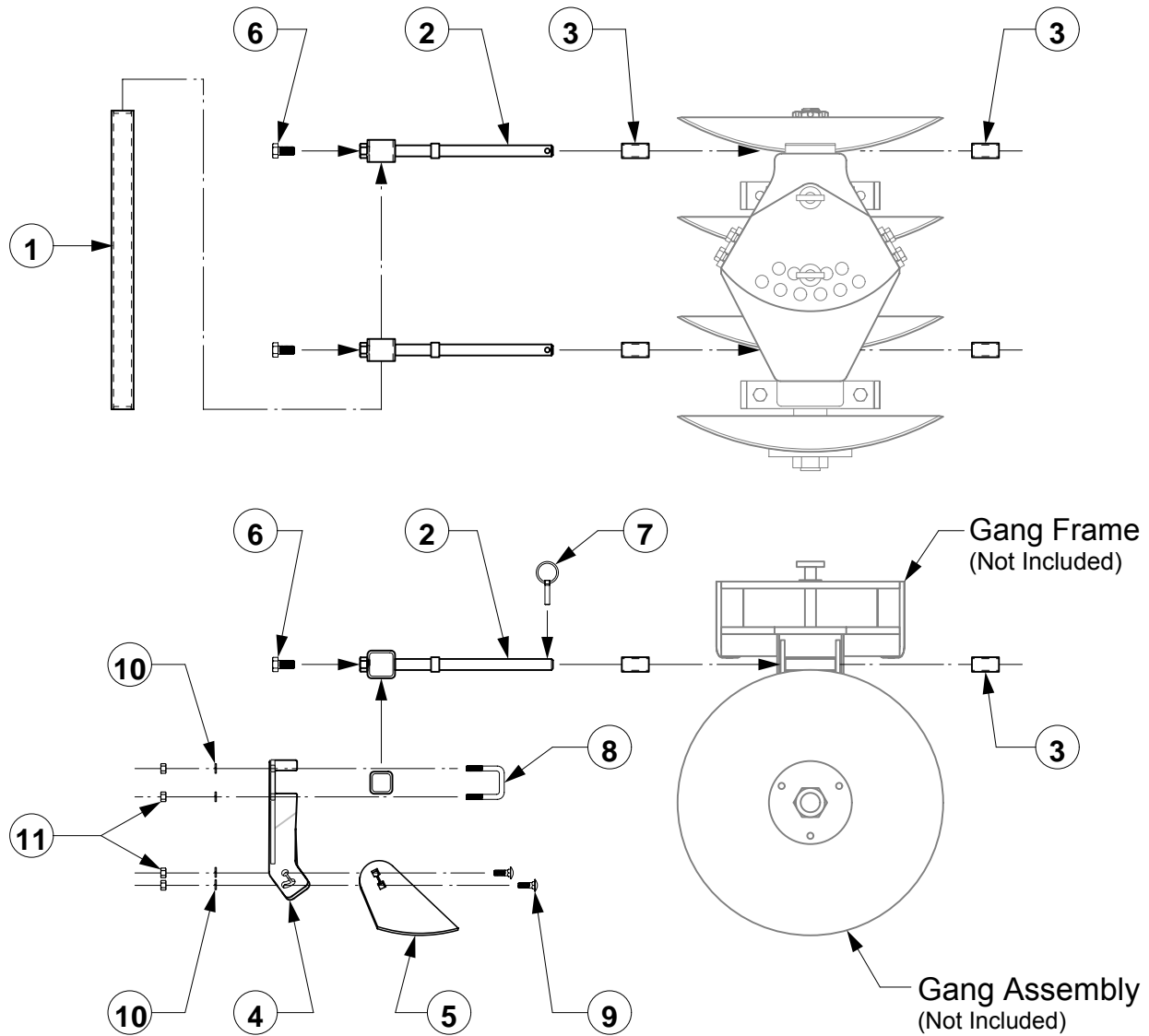

<u>Ref No.</u>	<u>New Part No.</u>	<u>Old Part No.</u>	<u>Description</u>	<u>Qty. / Kit</u>
1.	GDP-00J100	SDO-J1	Scraper Frame Cross Bar (specify blade qty.)	4
2.	GDP-00J200	SDO-J2	Scraper Frame Mounting Arm	8
3.	GDP-00J300	SDO-J3	Mounting Arm Spacer	16
4.	GDP-00K100L	SDO-K1	Disc Scraper Arm LH	Varies
	GDP-00K100R		Disc Scraper Arm RH	Varies
5.	GDP-00K200	SDO-K2	Disc Scraper	Varies
6.	CSNC512024	FHB075X0150	3/4" x 1-1/2" Gr. 5 Hex Bolt	8
7.	GPN-070LYN	FLP044X0175	7/16" x 1-3/4" Lynch Pin	8
8.	UBNC08X33S	FUB050X0300	1/2" x 3" Square Bend U-Bolt	1 per Scraper
9.	CBNC508024	FCB050X0150	1/2" x 1-1/2" Gr. 5 Carriage Bolt	2 per Scraper
10.	LWASHER-08	FLW050	1/2" Lock Washer	4 per Scraper
11.	HXNUT-08NC	FHN050	1/2" Hex Nut	4 per Scraper

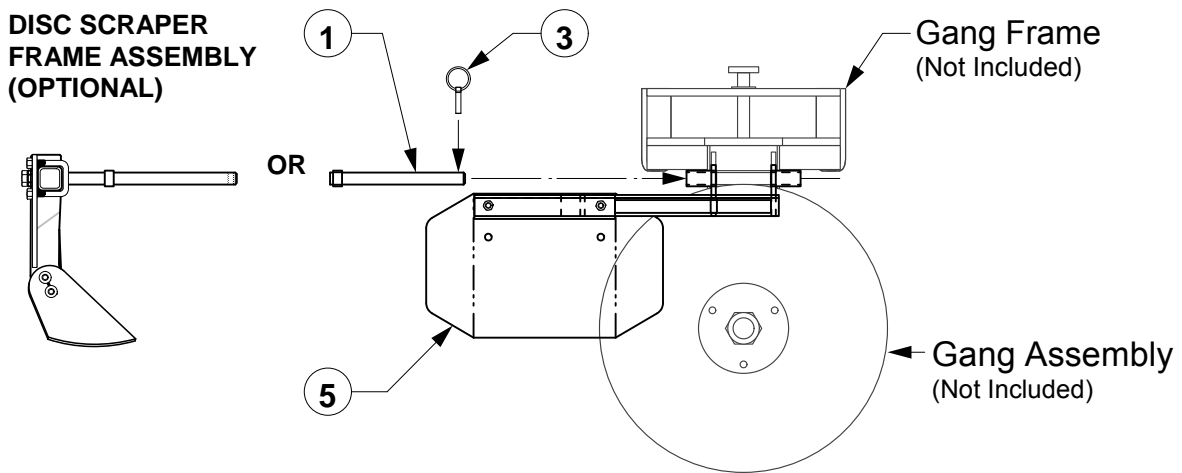
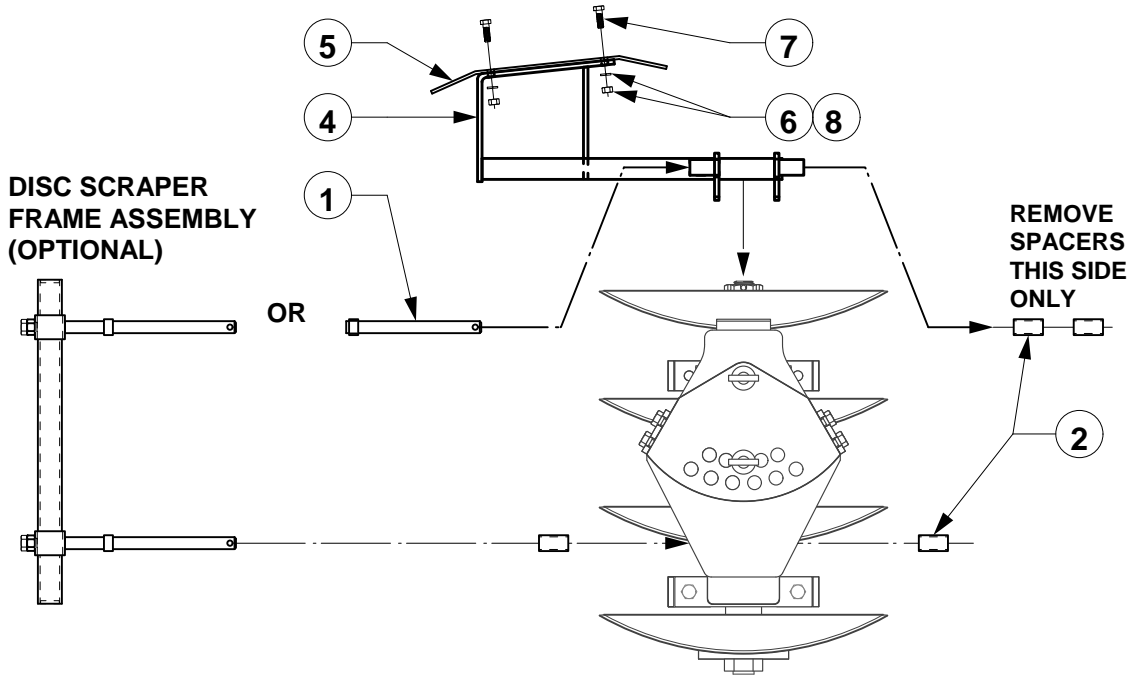

Ref No.	Old Part No.	New Part No.	Description	Qty.
1.	SDO-J2	GDP-00J200	Scraper Frame Mounting Arm	8
2.	SDO-J3	GDP-00J300	Mounting Arm Spacer	16
3.	FLP044X0175	GPN-070LYN	7/16" Lynch Pin	8
4.	-----	GDP-00L100L(R)	Dirt Shield Frame for 2,4,5-Blade Gangs LH or RH	2 or 4
		GDP-03L100L(R)	Dirt Shield Frame for 3-Blade Gangs LH or RH	2 or 4
5.	-----	GDP-00L200	12" Dirt Shield - Standard	1 per Frame
		GDP-00L400	14" Dirt Shield - Optional	1 per Frame
		GDP-00L500	18" Adjustable Dirt Shield - Optional	1 per Frame
6.	FHN050	HXNUT-08NC	1/2" Hex Nut	2 per Frame
7.	FCB050X0150	CSNC508024	1/2" x 1-1/2" Gr. 5 Cap Screw	2 per Frame
8.	FLW050	LWASHER-08	1/2" Lock Washer	2 per Frame

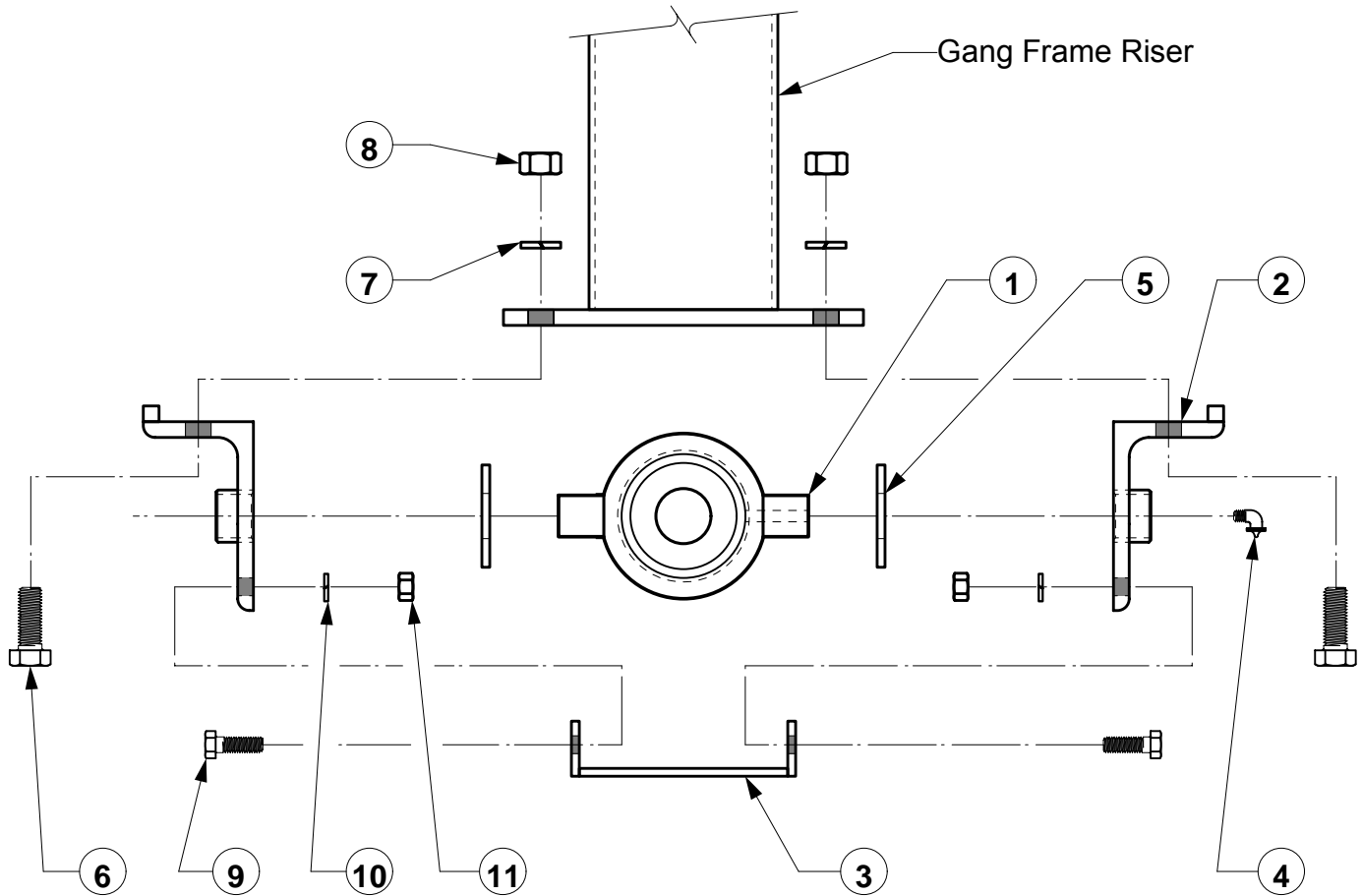

<u>Ref No.</u>	<u>New Part No.</u>	<u>Old Part No.</u>	<u>Description</u>	<u>Qty. / Gang</u>
1.	GDP-28TRB0	SD-175-TB	1-3/4" Trunnion Bearing Ass'y	2
2.	GDP-00E000	SD-175E	Trunnion Bearing Bracket	4
3.	GDP-00F000	SD-175F	Trunnion Bearing Wear Guard	2
4.	GMB-ZERK90	SD-175A-04	1/8" N.P.T. 90 Grease Zerk	2
5.	FWASHER-22	-----	1-3/8" Flat Washer z.p.	4
6.	CSNC512032	-----	3/4" x 2" Gr. 5 Hex Bolt z.p.	4
7.	LWASHER-12	-----	3/4" Lock Washer z.p.	4
8.	HXNUT-12NC	-----	3/4" Hex Nut z.p.	4
9.	CSNC508024	-----	1/2" x 1-1/2" Gr. 5 Hex Bolt z.p.	4
10.	LWASHER-08	-----	1/2" Lock Washer z.p.	4
11.	HXNUT-08NC	-----	1/2" Hex Nut z.p.	4



T. G. SCHMEISER CO., INC. TRUNNION BEARING ASSEMBLY - COMPLETE

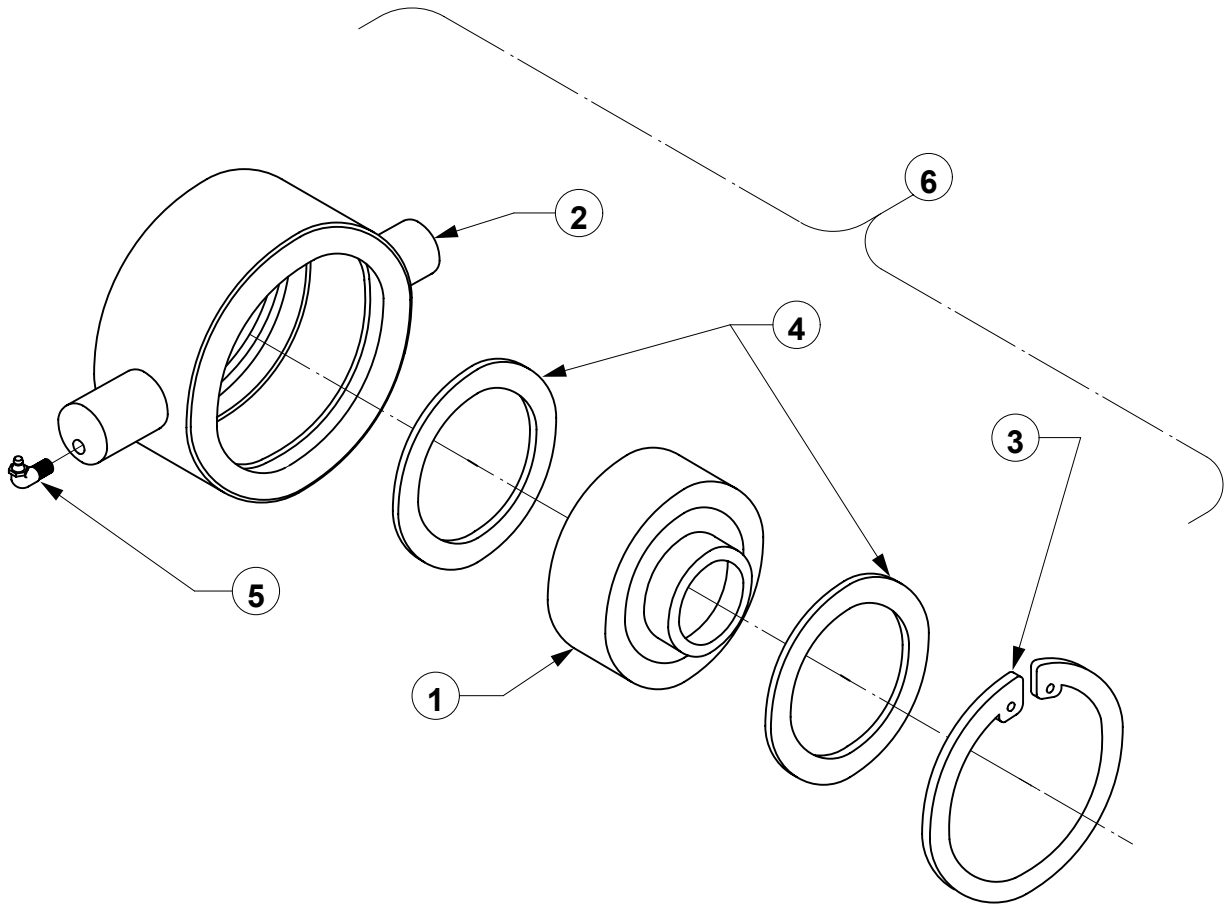

<u>Ref No.</u>	<u>Part No.</u>	<u>Description</u>	<u>Qty. / Ass'y</u>
1.	GDP-28TRB1	1-3/4" Trunnion Bearing Insert	1
2.	GDP-28TRB2	1-3/4" Trunnion Bearing Machined Housing	1
3.	GDP-28TRB3	1-3/4" Trunnion Bearing Snap Ring	1
4.	GDP-28TRB4	1-3/4" Trunnion Bearing Washer	2
5.	GMB-ZERK90	1/8" NPT 90 Threaded Zerk Fitting	1
6.	GDP-28TRB0	1-3/4" Trunnion Bearing Assembly Complete (includes all of the above items)	

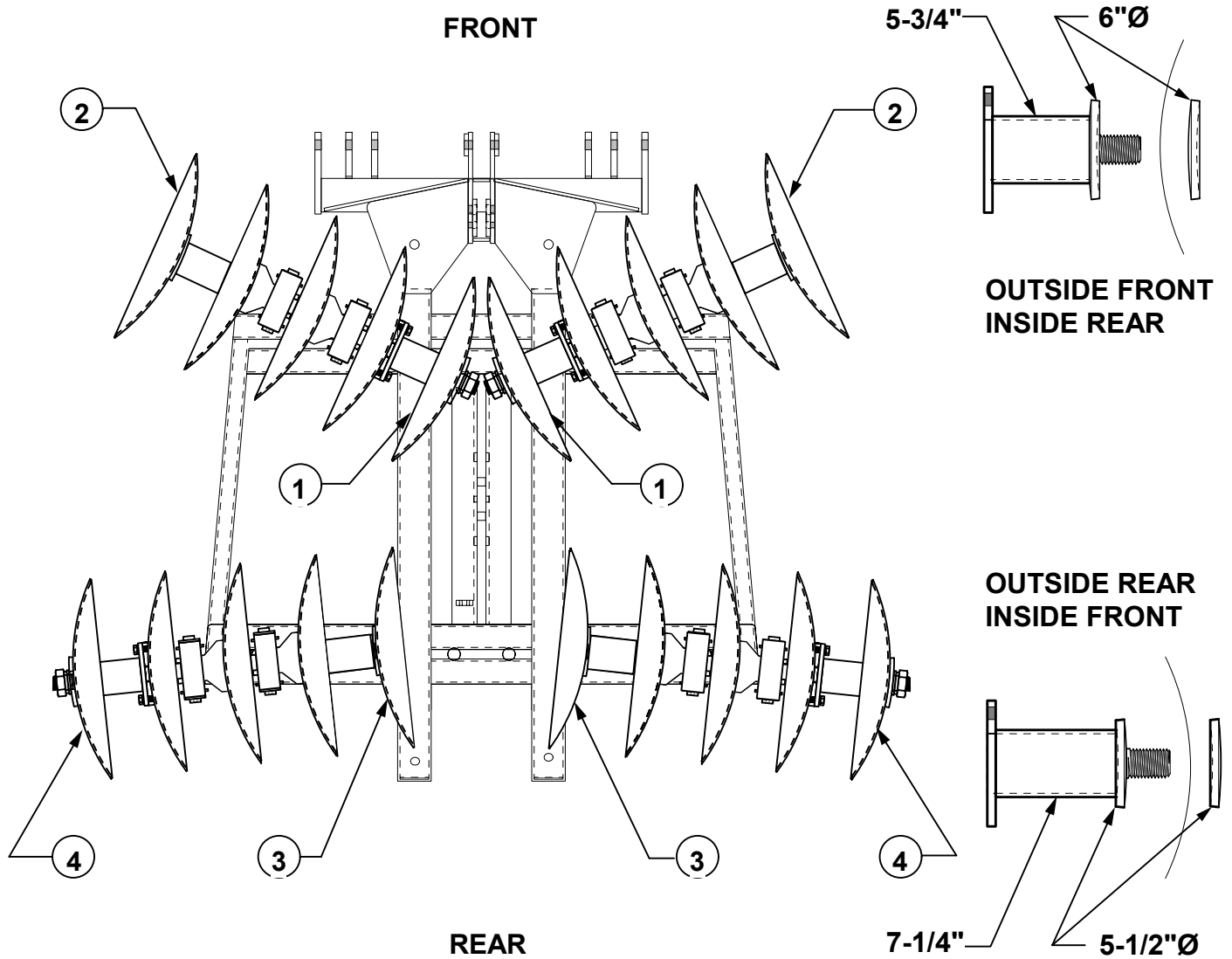

<u>Ref No.</u>	<u>Part No.</u>	<u>Description</u>	<u>Qty.</u>
1.	DBEIF	Disc Blade Extension Inside Front - Long	2
2.	DBEOF	Disc Blade Extension Outside Front - Short	2
3.	DBEIR	Disc Blade Extension Inside Rear - Short	2
4.	DBEOR	Disc Blade Extension Outside Rear - Long	2

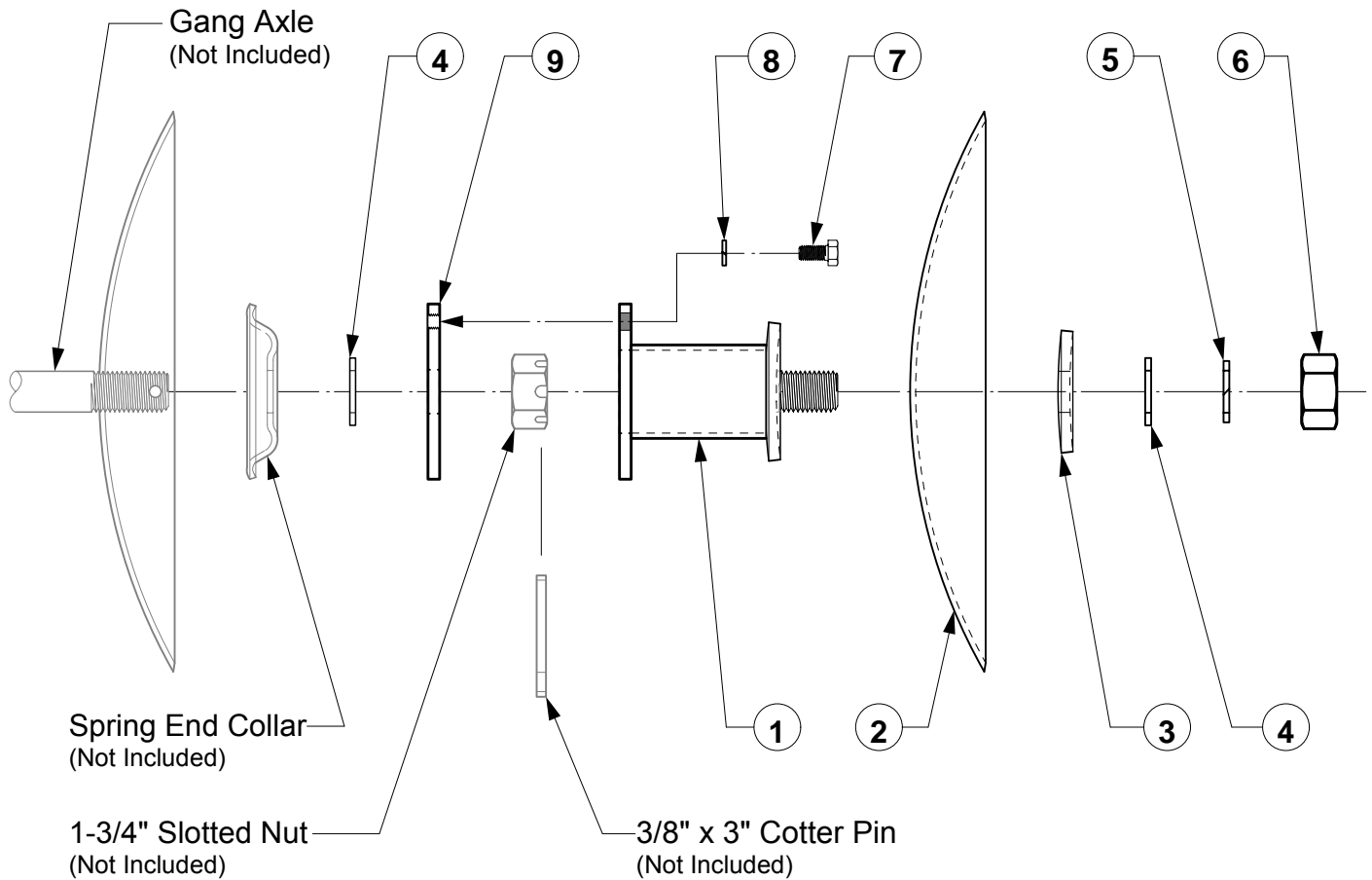

Note: Items "Not Included" are mounted on end of each disc gang axle.

<u>Ref No.</u>	<u>New Part No.</u>	<u>Old Part No.</u>	<u>Description</u>	<u>Qty. / Set</u>
1.	GDP-IBE000	SD-175ib	Inside Blade Extension	2
2.	-----	-----	Disc Blade	2
3.	GDP-28FS02	SD-175C-02	5-1/2" Dia. End Plate	2
4.	FWASHER-28	FFW175	1-3/4" Flat Washer	2
5.	LWASHER-28	FLW175	1-3/4" Lock Washer	2
6.	HXNUTJ28NC	FJN175	1-3/4" Jam Nut	2
7.	CSNC510020	FHB063X0125	5/8" X 1-1/4" Gr. 5 Hex Bolt	6
8.	LWASHER-10	FLW063	5/8" Lock Washer	6
9.	GDP-00I002	SDO-175i-02	Blade Extension Mounting Plate	2

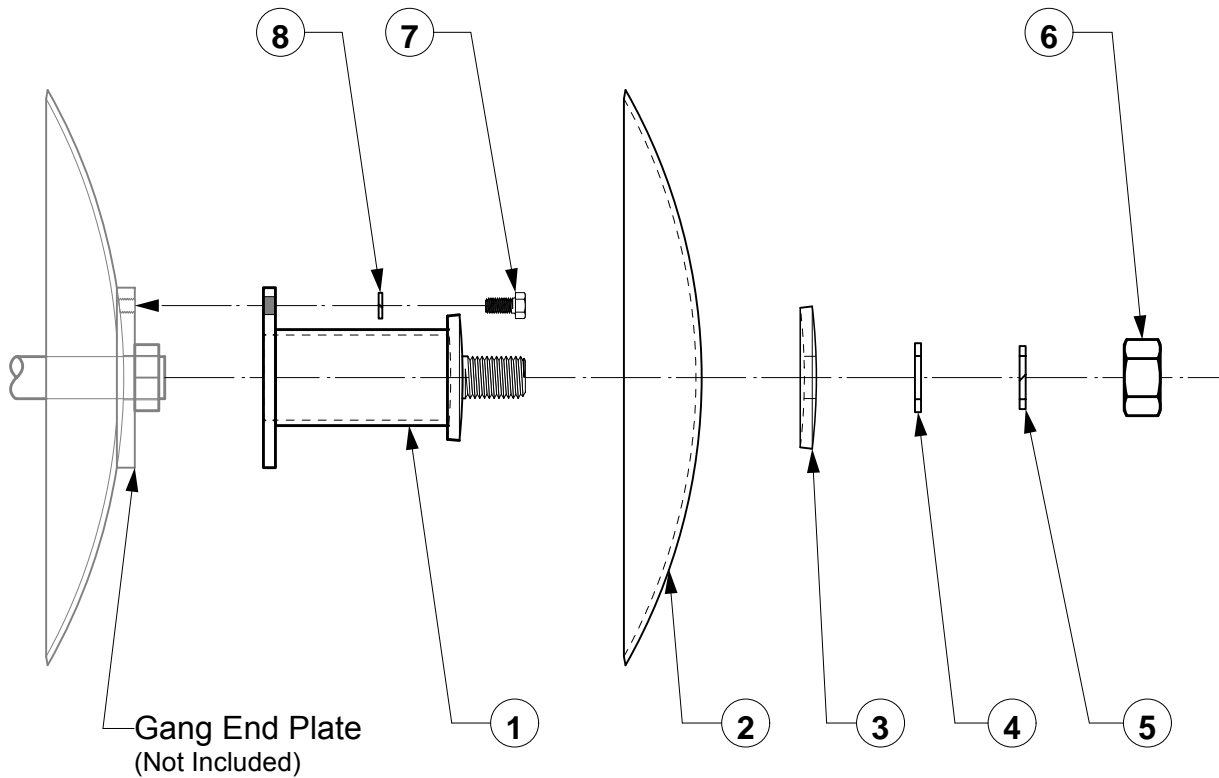

<u>Ref No.</u>	<u>New Part No.</u>	<u>Old Part No.</u>	<u>Description</u>	<u>Qty. / Set</u>
1.	GDP-OBE000	SD-175ia	Outside Blade Extension	2
2.	-----	-----	Disc Blade	2
3.	GDP-28FS01	SD-175C-01	6" Dia. End Plate	2
4.	FWASHER-28	FFW175	1-3/4" Flat Washer	2
5.	LWASHER-28	FLW175	1-3/4" Lock Washer	2
6.	HXNUTJ28NC	FJN175	1-3/4" Jam Nut	2
7.	CSNC510020	FHB063X0125	5/8" X 1-1/4" Gr. 5 Hex Bolt	6
8.	LWASHER-10	FLW063	5/8" Lock Washer	6

T.G. SCHMEISER CO., INC.®

Limited Warranty Statement

T. G. Schmeiser Co., Inc. warrants each new Schmeiser® product to be free from defects in material and workmanship. This warranty is applicable only for the normal service life expectancy of the product or components, not to exceed twelve (12) consecutive months from the date of delivery of the new Schmeiser product to the original purchaser.

Genuine T. G. Schmeiser Co., Inc. replacement parts and components will be warranted for 90 days from date of purchase, or the remainder of the original equipment warranty period, whichever is longer.

Under no circumstances will it cover any merchandise or components thereof, which, in the opinion of the company, has been subjected to misuse, unauthorized modifications, alteration, an accident or if repairs have been made with parts other than those obtainable through T. G. Schmeiser Co., Inc.

The Company in no way warrants engines, batteries, cylinders, tires or other trade accessories since these items are warranted separately by their respective manufacturer. Expendable components such as points, shanks, blades, rings, bearings, teeth, and the like are excluded from this warranty.

Our obligation under this warranty shall be limited to repairing or replacing, free of charge to the original purchaser, any part that, in our judgment, shall show evidence of such defect, provided further that such part shall be returned within thirty (30) days from date of failure to T. G. Schmeiser Co., Inc., routed through the dealer and distributor from whom the purchase was made, transportation charges prepaid.

This warranty shall not be interpreted to render T. G. Schmeiser Co., Inc. liable for injury or damages of any kind or nature to person or property. This warranty does not extend to the loss of crops, loss because of delay in harvesting, or any expense or loss incurred for labor, substitute machinery, rental or for any other reason.

Except as set forth above, T. G. Schmeiser Co., Inc. shall have no obligation or liability of any kind on account of any of its equipment and shall not be liable for special or consequential damages. T. G. Schmeiser Co., Inc. makes no other warranty, expressed or implied, and, specifically, T. G. Schmeiser Co., Inc. disclaims any implied warranty or merchantability or fitness for a particular purpose. Some states or provinces do not permit limitations or exclusions of implied warranties or incidental or consequential damages, so the limitations or exclusion in this warranty may not apply.

This warranty is subject to any existing conditions of supply, which may directly affect our ability to obtain materials or manufacture replacement parts.

T. G. Schmeiser Co., Inc. reserves the right to make improvements in design or changes in specifications at any time, without incurring any obligation to owners of units previously sold.

No one is authorized to alter, modify or enlarge this warranty nor the exclusion, limitations and reservations.

**WARRANTY VOID IF NOT REGISTERED
WITHIN 30 DAYS OF PURCHASE DATE**

Notes

A large rectangular box with a black border, containing 18 horizontal gray bars for writing notes. The bars are arranged in a repeating pattern of a gray bar followed by a white bar, starting from the top and ending at the bottom. The gray bars are approximately 15 pixels high and span the width of the box. The white bars are approximately 15 pixels high and also span the width of the box. The entire box is empty, with no text or other markings inside.